

MDRW Series

MDRW50

DC/DC converters for railway application



1. Description

MDRW – ultra-compact isolated DC to DC converters for railway application. Despite its dimensions MDRW output power reaches up to 50 W. It has several features: wide range of operating temperatures (ambient -40...+85 °C), Remote On/Off, full range of protections: overcurrent, over-temperature, short circuit.

Internal configuration without optocouplers allows it to operate in high-temperatures conditions during all lifetime period. Polymer potting guarantees a high level of environmental protection as well as vibration, dust, humidity and salt mist. Every unit is tested for thermal resistance, including burn-in test in extreme power on/off mode.

1.1. Engineered in accordance with

- EN 50155
- EN 61373
- EN 50121-3-2
- EN 55032
- EN 61000-6-2 Class A

1.2. Features

- Warranty 5 years
- 1/4 Brick case
- Output current up to 10A
- Low profile design (12,7 mm)
- Short-circuit, overvoltage, thermal protection
- No-load operation
- Remote on/off
- Ultra-wide input voltage range 33...160VDC with transient deviation 25...166VDC
- Isolation voltage 2500VDC

1.3. Additional information

1.3.1. Description on the manufacturer's website

eng.aedon.ru/catalog/dcdc/series/21



1.3.2. Order registration

+7 473 300-300-5, Global Operations Team

2. Contents

1. Description	1	5.3. U_{OUT} trimming.....	6
1.1. Engineered in accordance with.....	1	5.3.1. Resistor connection.....	6
1.2. Features.....	1	5.3.2. Resistor nominals diagram.....	7
1.3. Additional information.....	1	6. Test reports	8
1.3.1. Description on the manufacturer’s website.....	1	6.1. Efficiency and P_{OUT}/T_{AMB} dependence.....	8
1.3.2. Order registration.....	1	6.1.1. MDRW50N05.....	8
1.3.3. Technical support.....	1	6.1.2. MDRW50N12.....	8
2. Contents	2	6.1.3. MDRW50N15.....	8
3. Part number	2	6.1.4. MDRW50N24.....	9
4. Specifications	3	6.1.5. MDRW50N36.....	9
4.1. General specifications.....	3	6.1.6. MDRW50N48.....	9
4.2. Input specifications.....	3	6.2. Oscillograph charts.....	10
4.3. Output specifications.....	3	6.2.1. MDRW50N24.....	10
4.4. Protections.....	4	6.3. Noise spectrogram.....	11
4.5. Physical specifications.....	4	6.3.1. MDRW50N05.....	11
5. Diagrams	5	7. Outline dimensions	12
5.1. Layout.....	5		
5.2. Connection diagrams.....	5		
5.2.1. Typical connection diagram.....	5		
5.2.2. Typical circuit for EN55032 Class B compliance.....	6		

3. Part number

For more information please contact our Global Operations Team: +7 473 300-300-5

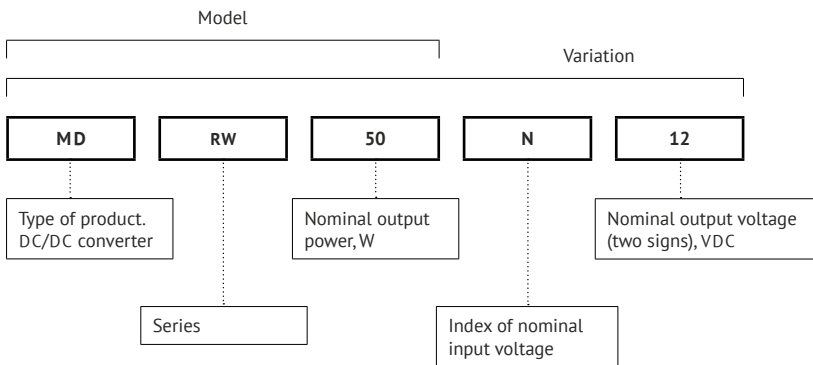

4. Specifications

All specifications valid for normal climatic conditions (ambient temp. 15...35 °C; relative humidity 45...80 %; air pressure $8,6 \times 10^4 \dots 10,6 \times 10^4$ Pa), $U_{IN,NOM}$, $I_{OUT,NOM}$, unless otherwise stated. It is important to note that the information herein is not full.

4.1. General specifications

Parameter	Symbol	Conditions	Value	Unit
Operating case temperature	T_{CASE}		-40...+100	°C
Operating ambient temperature	T_{AMB}	Case temperature in standard limits	-40...+85	°C
Storage temperature			-50...+110	°C
Switching frequency			150-180	kHz
Isolation voltage @ 60 s		Input/output, input/case, output/case	2500	VDC
Isolation resistance @ 500 VDC		Normal climatic conditions	>100	MOhm
Thermal impedance			7,51	°C/W
Remote on/off			Off.: 0...1,5 VDC or connection of pins "ON" and "-IN", $I \leq 5$ mA	
MTBF		$T_{CASE}=70$ °C, $P=70$ %	1 400 000	hrs
Warranty			5	years

4.2. Input specifications

Parameter	Symbol	Conditions	Value	Unit
Nominal input voltage	$U_{IN,NOM}$	Index "N"	72	VDC
Input voltage range			33...160	VDC
Transient deviation U_{IN}		During 1 s	(25 ^[1])28...166	VDC

4.3. Output specifications

Parameter	Symbol	Conditions	Value	Unit
Output power	P_{OUT}		50	W
Typical efficiency	EFF	$U_{IN}=72$ VDC, $U_{OUT}=12$ VDC	86	%
Quantity of output channels			1	
Nominal output voltage	$U_{OUT,NOM}$		5; 12; 15; 24; 36; 48	VDC
Output current (min)	$I_{OUT,MIN}$		0	
Output current (max)	$I_{OUT,MAX}$	$P_{OUT}=50$ W	10	A
Output voltage adjustment			+10...-20	%
Steady-state output voltage deviation, $U_{OUT,NOM}$		$U_{IN,NOM}$, $I_{OUT,MAX}$, normal climatic conditions	max ±1	%
Voltage regulation, $U_{OUT,NOM}$		Gradual change of U_{IN} within set value range	max ±0,75	%
		Gradual change of I_{OUT} within $0,05 \dots 1 \times I_{OUT,MAX}$	max ±0,75	%
		Thermal instability	max ±2	%
		Repeatability	max ±0,5	%
		Total voltage regulation within the complete range of U_{IN} , I_{OUT} and T_{AMB}	max ±4	%
Ripple and noise (p-p), $U_{OUT,NOM}$	U_{p-p}		<1	%

[1] It remains possible a 15% $P_{out,nom}$. reducing in case of 25...28 VDC transient range..

Parameter	Symbol	Conditions	Value	Unit
Max total capacitance of output capacitors	$C_{OUT.MAX}$	$U_{OUT}=5$ VDC	8000	μ F
		$U_{OUT}=12$ VDC	1300	
		$U_{OUT}=15$ VDC	1000	
		$U_{OUT}=24$ VDC	330	
		$U_{OUT}=36$ VDC	170	
		$U_{OUT}=48$ VDC	100	
Start up time		by input voltage, $I_{OUT.MAX}$, $C_{OUT.MAX}$	<100	ms
		by Remote ON/OFF, $I_{OUT.MAX}$, $C_{OUT.MAX}$	<35	ms
Transient response deviation, $U_{OUT.NOM}$		On change $U_{IN.NOM}$ 0,6...1,4 $\times U_{IN.NOM}$ (during 0,1 ms); On change 1.25 $\times I_{OUT}$ front time $\leq 0,1$ A/ μ s	max ± 5	%
Parallel operation			no	
Remote sense		Line-drop compensation up to 10% $U_{OUT.NOM}$	yes	

4.4. Protections

Parameters are stated for the information purposes and could not be used for long term operation, over current operation, operation out of stated temperature limits.

Parameter	Symbol	Conditions	Value	Unit
Overcurrent protection I_{OUT}			1,3...1,4 I_{NOM}	
Thermal protection			115 \pm 10 °C (latching with automatic recovery)	
Short-circuit protection			yes, with auto recovery after short-circuit clearance	
Output overvoltage			1,3 $U_{OUT.NOM}$	
Vibration proof			10...2000 Hz, 200 (20) m/s ² (g), 0,3 mm	
Shielding			yes	
Potting			yes	
Dust proof			yes	
Salt fog resistant			yes	
Moisture proof		98% at $T_{AMB} = 35$ °C	yes	
Resistance to mechanical stress			yes	

4.5. Physical specifications

Parameter	Symbol	Conditions	Value	Unit
Form-factor			1/4 Brick	
Heatsink			separate	
Case material			duralumin	
Coating			microarc oxidation	
Pin material			bronze/brass	
Weight			max 95	g
Type of contacts			pins for PCB soldering	
Soldering temperature		5 s	260	°C
Dimensions		Without output pins	max 58,4 \times 36,8 \times 12,7	mm

5. Diagrams

5.1. Layout

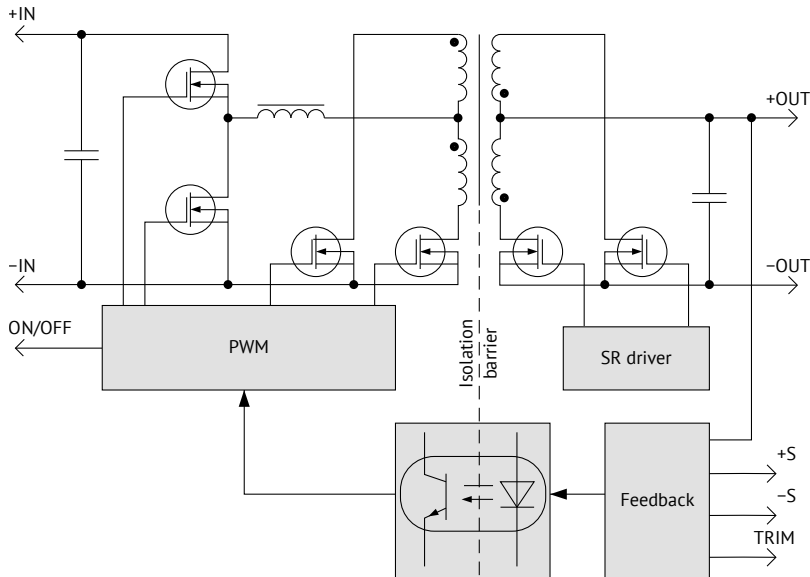

Figure 1. MDRW50 layout.

5.2. Connection diagrams

5.2.1. Typical connection diagram

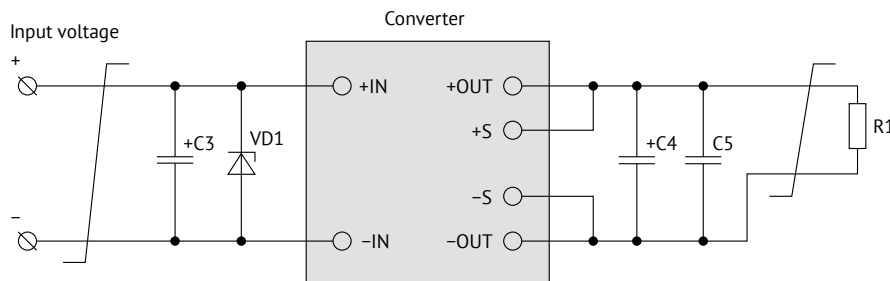

Figure 2. MDRW50 typical connection diagram.

C3 – 120 μ F Low ESR.

VD1 – suppressor SMBJ160A.

C5 – ceramic capacitor MLCC 1 μ F.

C4 – capacitance is stated below:

U_{OUT}	C4	Type	ESR
5 VDC	2×470 μ F	polymer	<14 mOhm
12 VDC	2×220 μ F	polymer	<12 mOhm
15 VDC	2×220 μ F	polymer	<15 mOhm
24 VDC	2×33 μ F	polymer	<16 mOhm
36; 48 VDC	15 μ F	polymer	<40 mOhm

5.2.2. Typical circuit for EN55032 Class B compliance

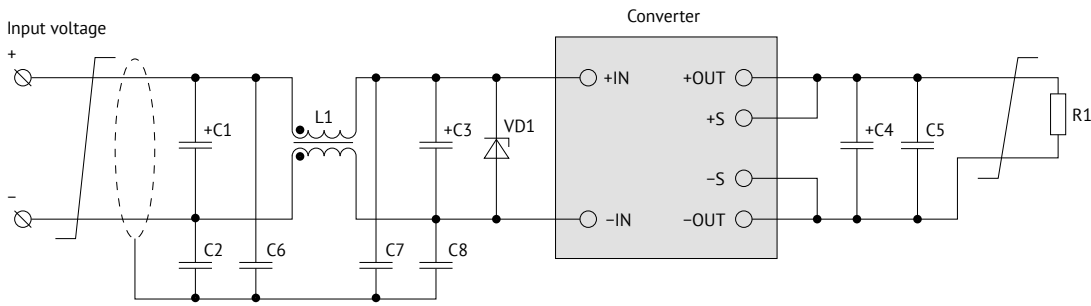

Figure 3. MDRW50 connection circuit for EN55032 Class B..

C1, C3 – 120 μ F Low ESR.

C2, C6, C7, C8 – ceramic capacitor MLCC 2,2 nF.

C5 – ceramic capacitor MLCC 1 μ F.

L1 – common mode choke ≥ 1 mH.

VD1 – suppressor SMBJ160A.

C4 – capacitance is stated below:

U_{OUT}	C4	Type	ESR
5 VDC	2x470 μ F	polymer	<14 mOhm
12 VDC	2x220 μ F	polymer	<12 mOhm
15 VDC	2x220 μ F	polymer	<15 mOhm
24 VDC	2x33 μ F	polymer	<16 mOhm
36; 48 VDC	15 μ F	polymer	<40 mOhm

Please note: input and output capacitors can consist of several parallel connected capacitors; ESRmax is stated for 100 kHz, 20 °C.

5.3. U_{OUT} trimming

5.3.1. Resistor connection

To trim down $U_{OUT,NOM}$ you should connect a resistor between “TRIM” and “+S” pins. To trim up – between “TRIM” and “-S” pins. Please see details below.

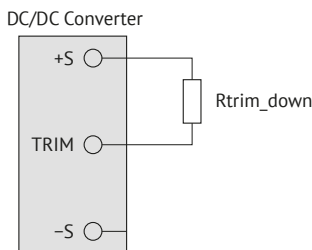

Figure 4. Resistor connection for $U_{OUT,NOM}$ trim down.

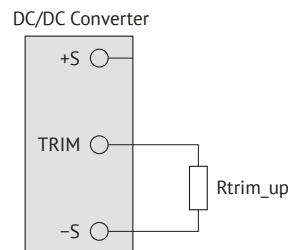

Figure 5. Resistor connection for $U_{OUT,NOM}$ trim up.

5.3.2. Resistor nominals diagram

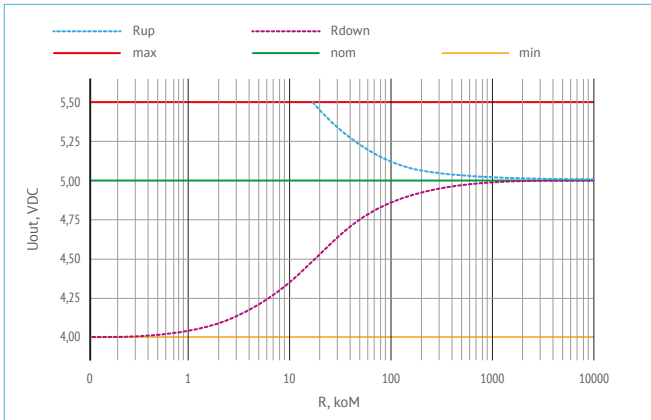

Figure 6. Chart for MDRW50N05.

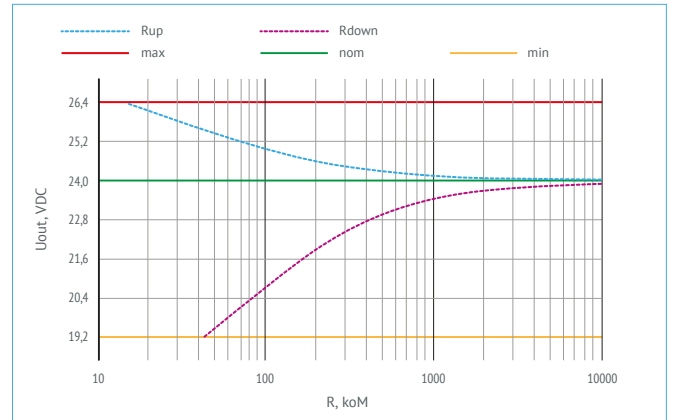

Figure 9. Chart for MDRW50N24.

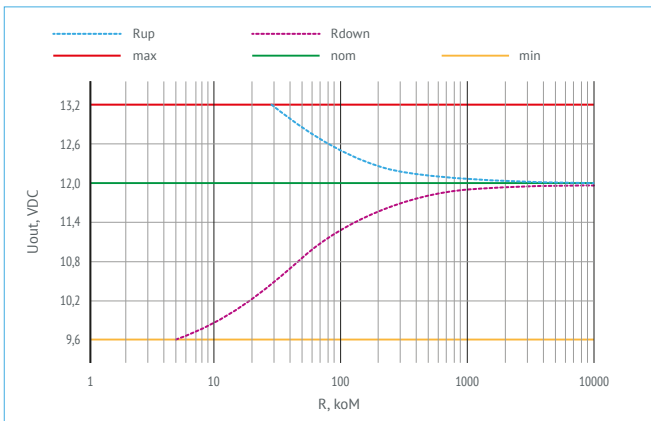

Figure 7. Chart for MDRW50N12.

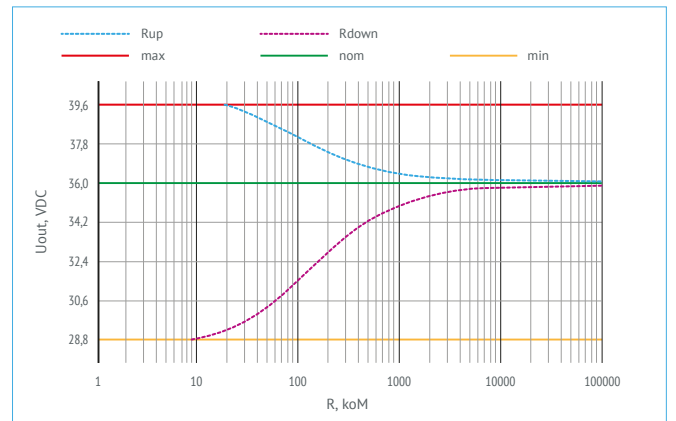

Figure 10. Chart for MDRW50N36.

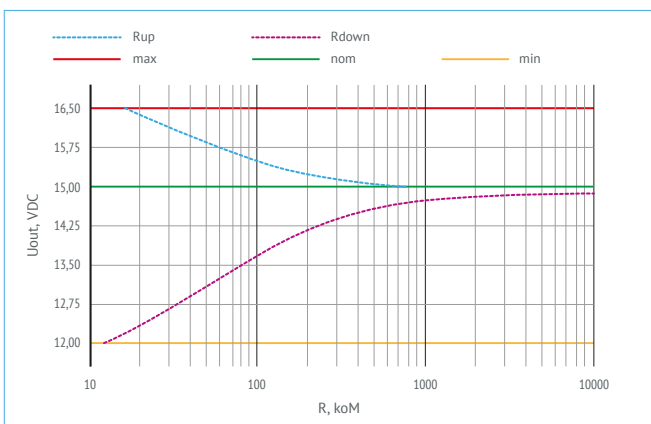

Figure 8. Chart for MDRW50N15.

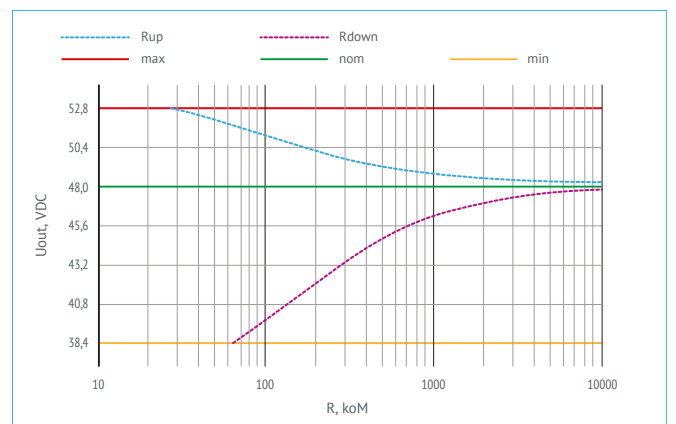

Figure 11. Chart for MDRW50N48.

6. Test reports

6.1. Efficiency and P_{OUT}/T_{AMB} dependence

6.1.1. MDRW50N05

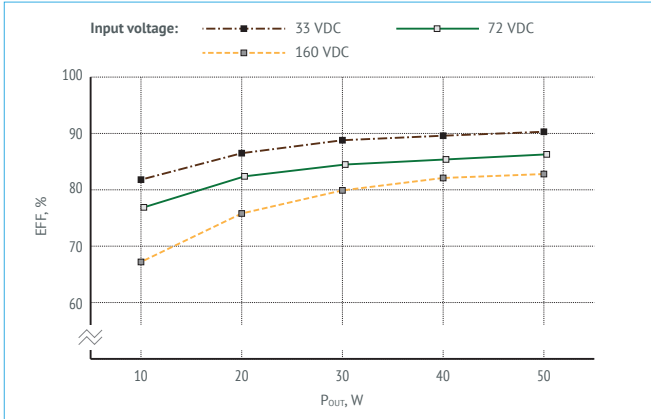

Figure 12. Efficiency.

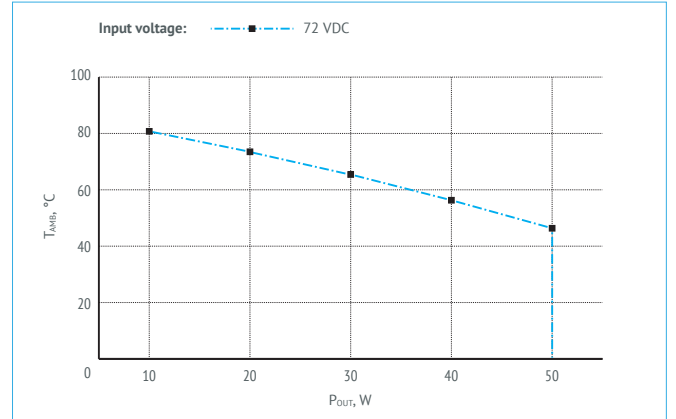

Figure 13. P_{OUT} vs T_{AMB} chart.

6.1.2. MDRW50N12

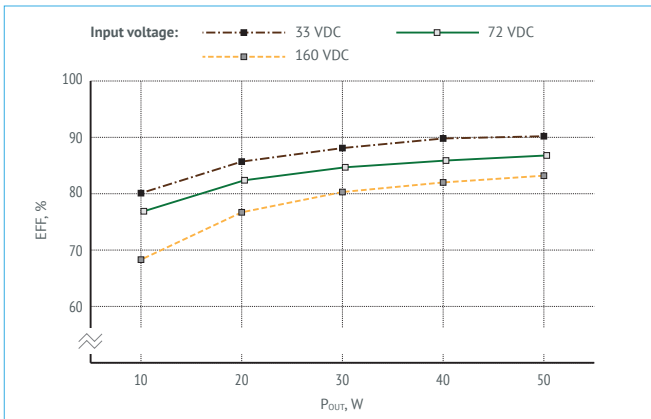

Figure 14. Efficiency.

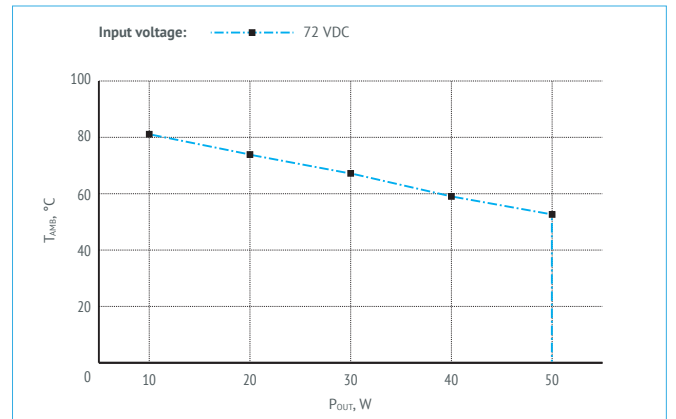

Figure 15. P_{OUT} vs T_{AMB} chart.

6.1.3. MDRW50N15

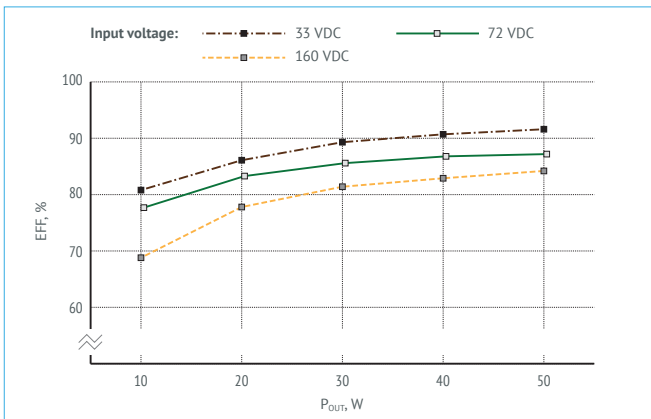

Figure 16. Efficiency.

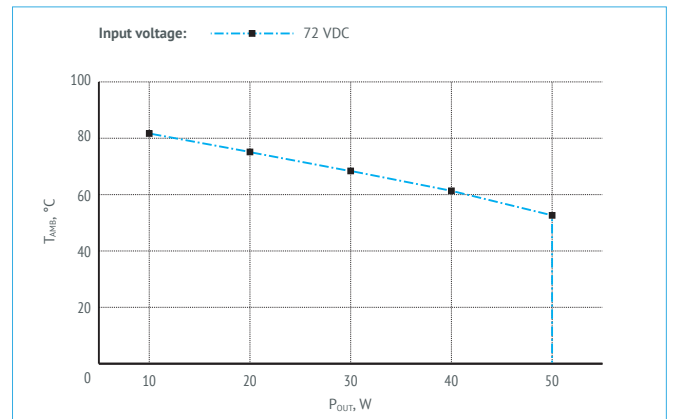

Figure 17. P_{OUT} vs T_{AMB} chart.

6.1.4. MDRW50N24

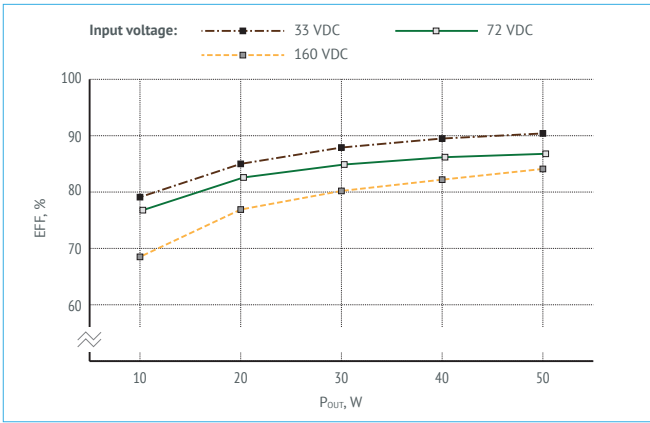

Figure 18. Efficiency.

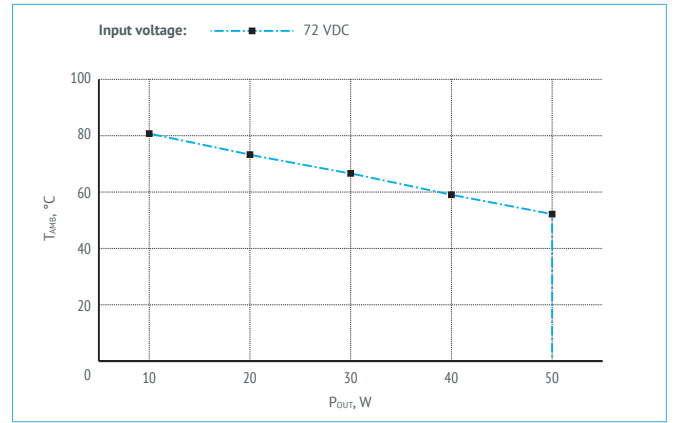

Figure 19. P_{OUT} vs T_{AMB} chart.

6.1.5. MDRW50N36

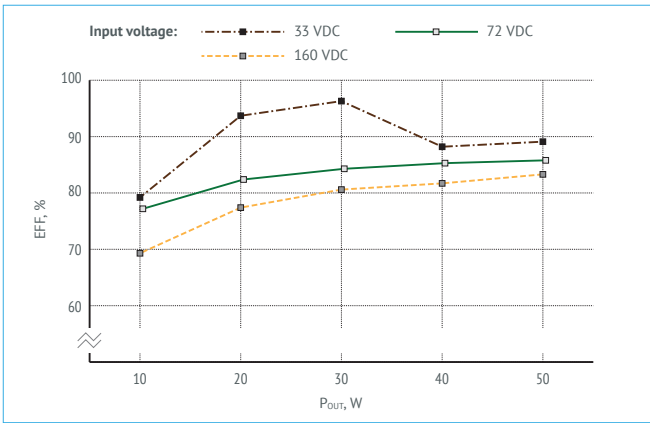

Figure 20. Efficiency.

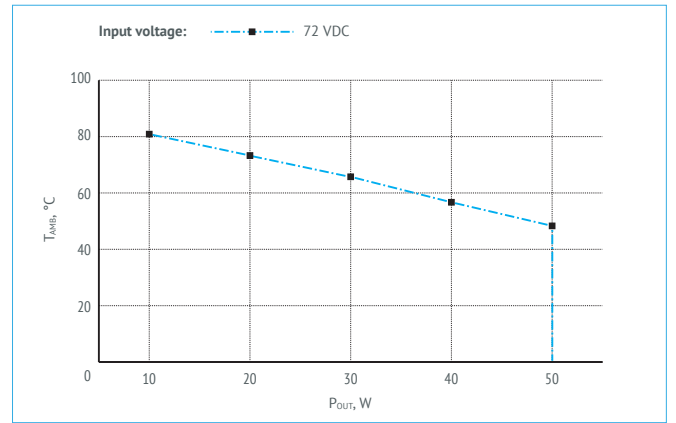

Figure 21. P_{OUT} vs T_{AMB} chart.

6.1.6. MDRW50N48

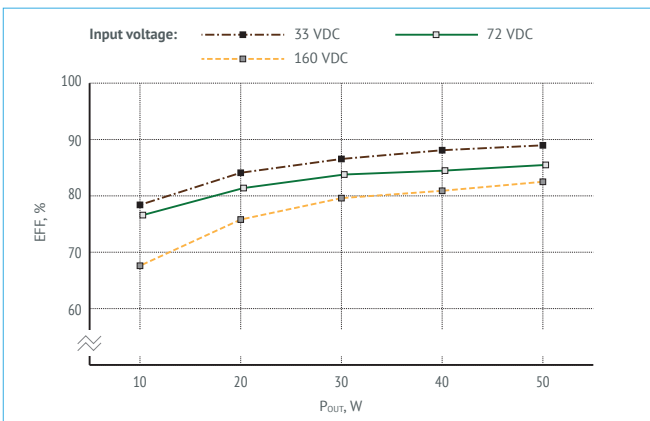

Figure 22. Efficiency.

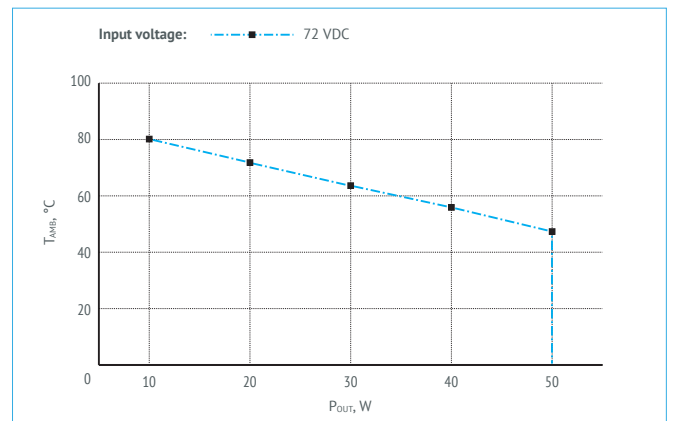

Figure 23. P_{OUT} vs T_{AMB} chart.

6.2. Oscillograph charts

6.2.1. MDRW50N24



Figure 24. $U_{OUT,NOM}$ stabilizing with Remote On/Off option (ON and -OUT pins connection).

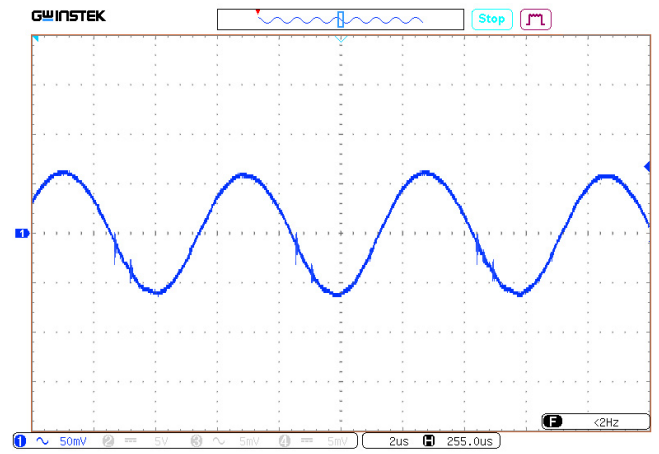

Figure 27. $U_{OUT,NOM}$ ripple.

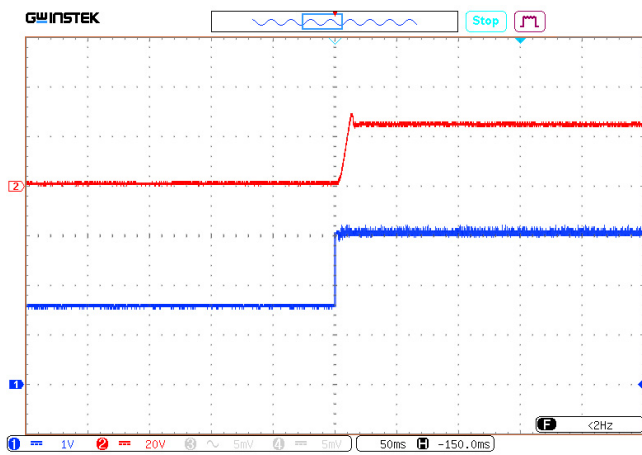

Figure 25. $U_{OUT,NOM}$ stabilizing with Remote On/Off option (control signal).

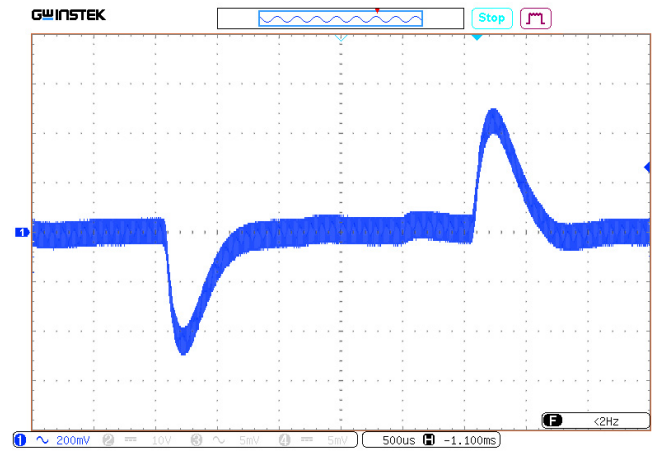

Figure 28. $U_{OUT,NOM}$ transient deviation on $0,75...1 \cdot I_{OUT}$ change.

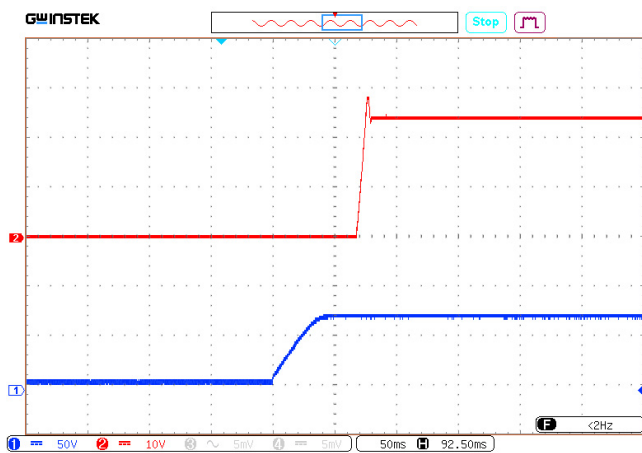

Figure 26. $U_{OUT,NOM}$ stabilizing with $U_{IN,NOM}$.

6.3. Noise spectrogram

6.3.1. MDRW50N05

EN55032 Class B compliance tests.

Conditions: $U_{IN}=72$ VDC, $T_{AMB}=25$ °C.

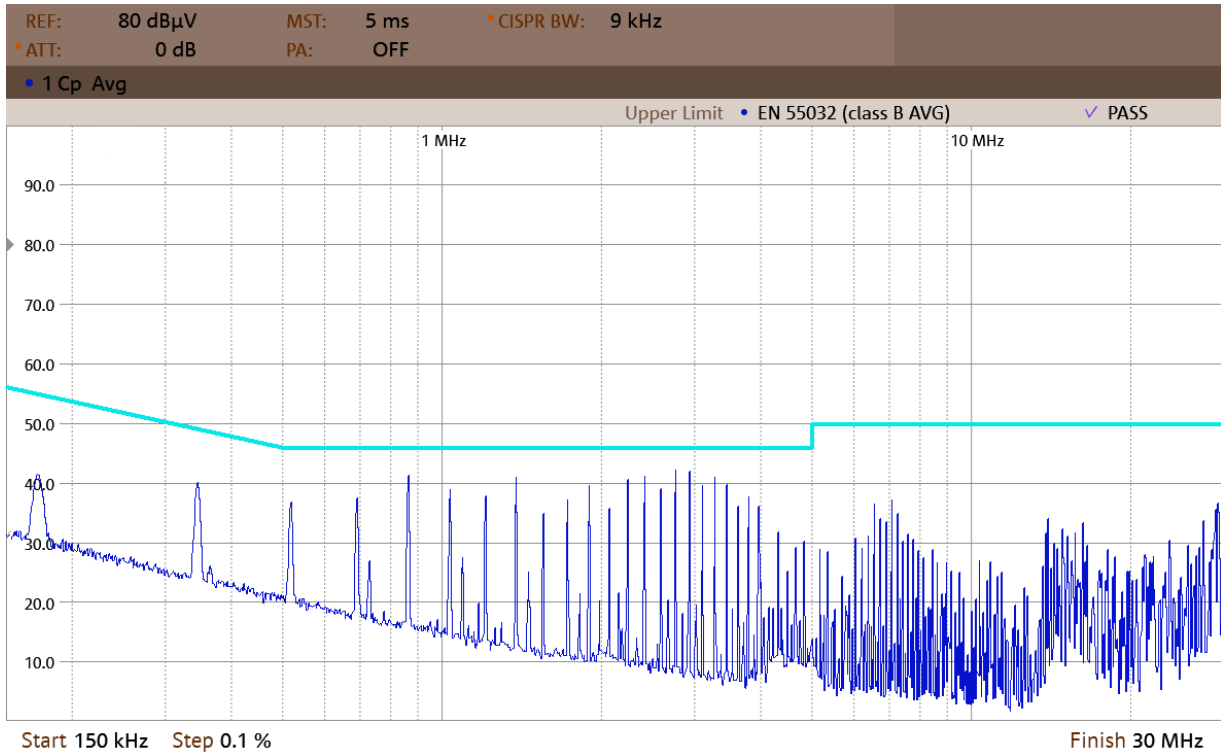

Figure 29. Spectrogram 0,15–30 MHz.

7. Outline dimensions

Pin #	1	2	3	4	5	6	7	8
Function	+IN	Remote On/Off	-IN	-OUT	-S	TRIM	+S	+OUT

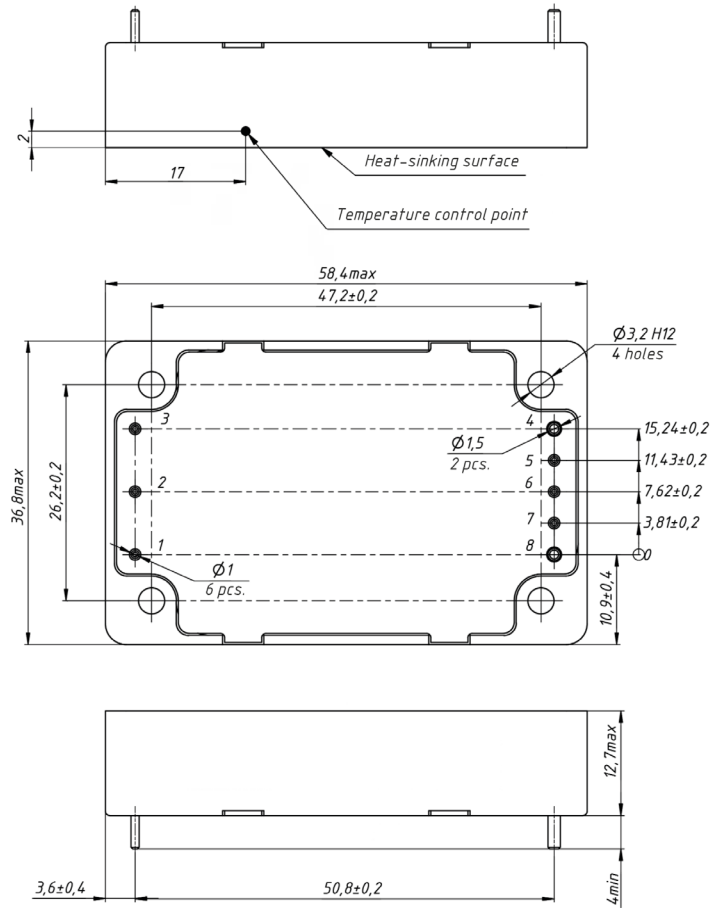

Figure 30. 1/4 Brick.



eng.aedon.ru

mail@aedon.ru

AEDON, LLC is the leading Russian developer and manufacturer of DC/DC converters and power supply systems for critical applications.

This datasheet is valid for the following units: MDRW50N05; MDRW50N12; MDRW50N15; MDRW50N24; MDRW50N36; MDRW50N48.